

# TECNA®



Advanced Resistance Welding Systems and Balancers



## **3680P | 3680P7**

### **TRAFO ZANGE - VOLLAUTOMATISCH**

**WIDERSTANDSSCHWEISSANLAGE FÜR KAROSSERIEBETRIEBE**

[www.tecna.net](http://www.tecna.net)

Spot welding solutions



# 3680

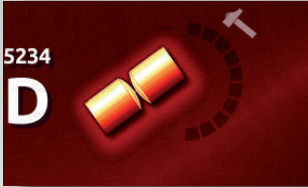

Wi-Fi  
Automatische Updates  
Bericht aus der Ferne ausgeführt  
Remoteunterstützung

Schweißstrom  
**14000 A**

TRAFO ZANGE VOLLAUTOMATISCH



3680P

3680P7

23221P



SOFTWARE PROGRAMM

72000/3680



3591 (OPTIONAL)



## 8679TS



**FORCE**  
**450**  
daN

**GYRO**  
**360°**  
SCOPE

**Smart**  
**PLUS**

STANDARD MIT 3680P

## 8679TS7



**FORCE**  
**700**  
daN

**GYRO**  
**360°**  
SCOPE

**Smart**  
**PLUS**

STANDARD MIT 3680P7



**NEW**

TECHNISCHE DATEN	3680P 8679TS	3680P7 8679TS7	3680P 8679TS	3680P7 8679TS7
Netzspannung	*400 VACx3~50 Hz		*220 VACx3~50/60 Hz	
Absicherung	32 A - träge		50 A - träge	
Schweißstrom	14.000 A			
Fassungsvermögen - Wassertank	25 l			
Abmessung:Höhe/Breite/Tiefe	237 / 63 / 81 cm			
Gesamtgewicht ohne Zubehör	140 kg			
"C" - Zange	8679TS	8679TS7	8679TS	8679TS7
Kabellänge	4 m	4 m	6 m	6 m
Nennleistung 50%	19 kVA	19 kVA	19 kVA	19 kVA
Maximale Schweißleistung	60 kVA	60 kVA	60 kVA	60 kVA
Wärmestrom 100%	1,8 kA	1,8 kA	1,8 kA	1,8 kA
Leerlaufspannung	8,7 V	8,7 V	8,7 V	8,7 V
Maximale Elektrodenkraft (8 bar)	450 daN	700 daN	450 daN	700 daN
Erkennungssensor	S	S	S	S
Zangengewicht ohne Arme	12,5 kg	12,5 kg	12,5 kg	12,5 kg

\* Unterschiedliche Spannungen und Frequenzen auf Anfrage.

S = Smart Plus

## OPTIONALS

### 8691



### 8691/7

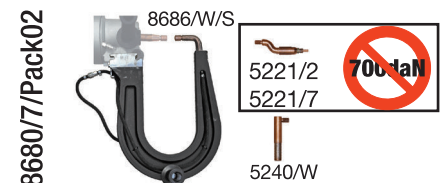
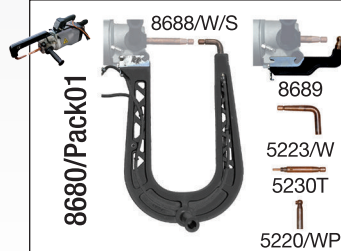

# ARME / ELEKTRODEN

8679H | 8679TS

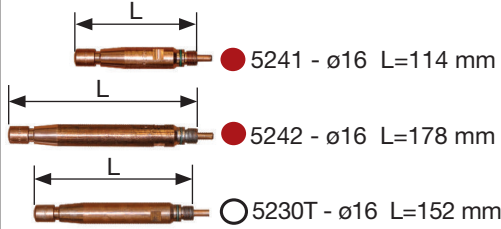

8679TS7

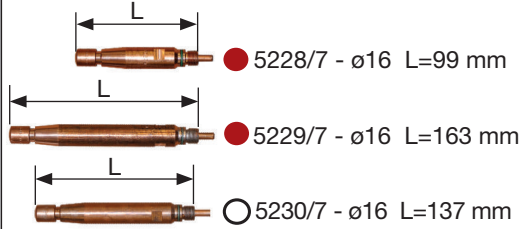

Ø 16

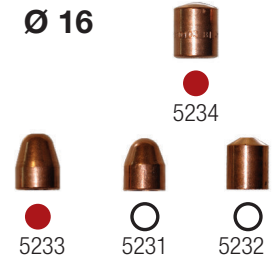

● STANDARD ○ OPTIONAL

5233/C

5234/C

5235K



5233 - n°12

5234 - n°12

5233 - n°16

5234 - n°36

5227/W-Ø16 mm

● 8685/W/S

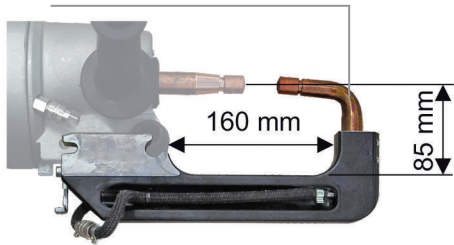

○ 8688/W/S

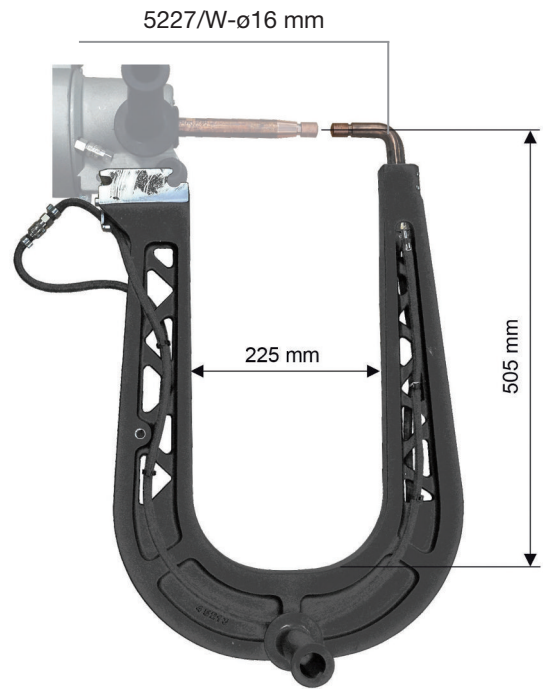

5227/W-Ø16 mm

○ 8684/W/S

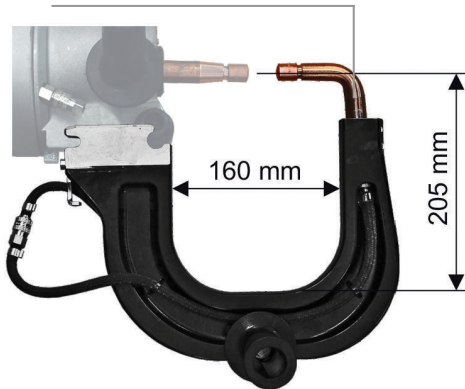

○ 8687/W/S

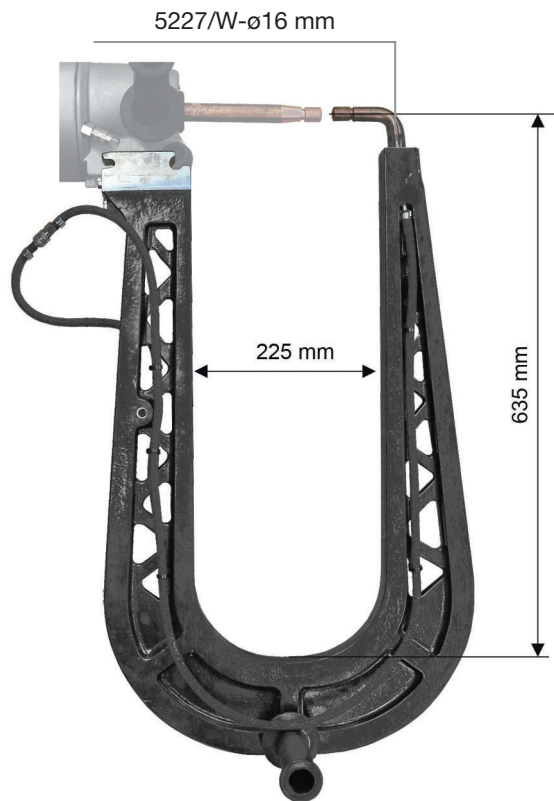

5227/W-Ø16 mm

○ 8686/W/S

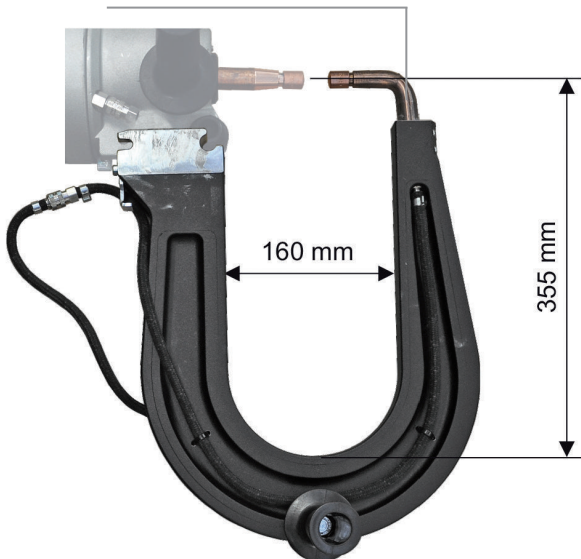

ARME - ELEKTRODEN

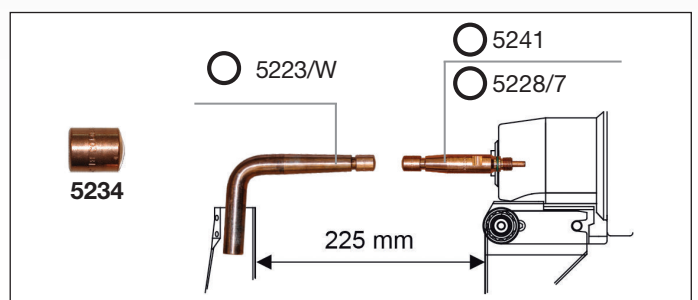
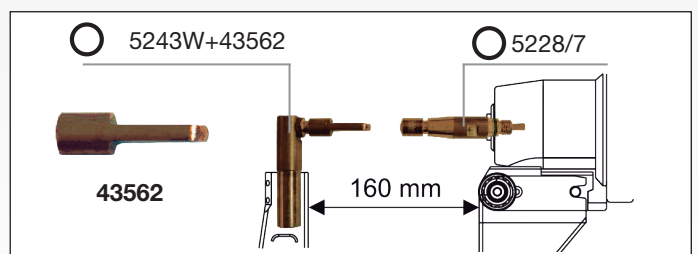
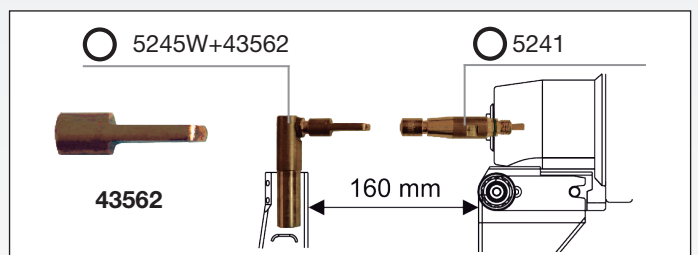
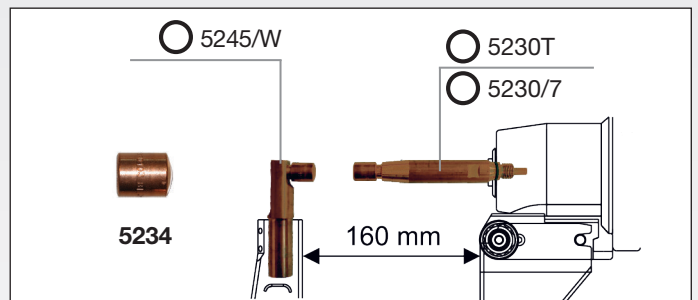
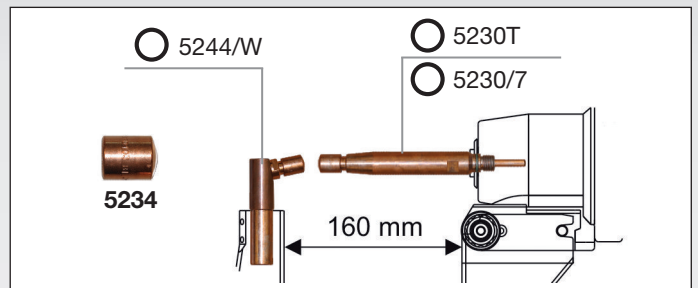
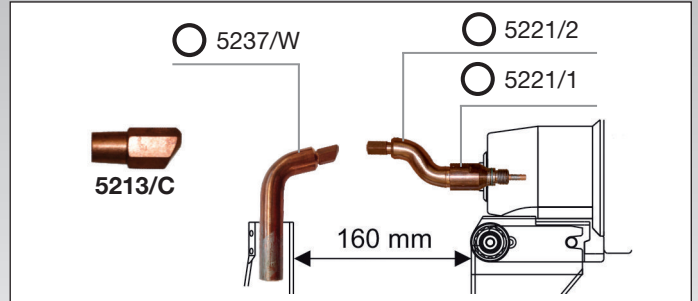
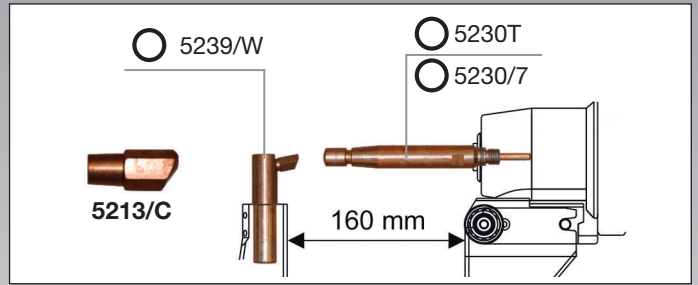
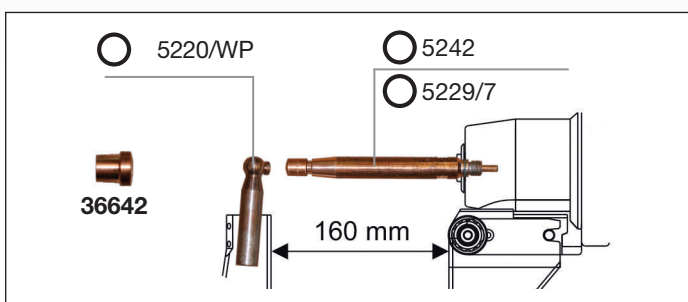
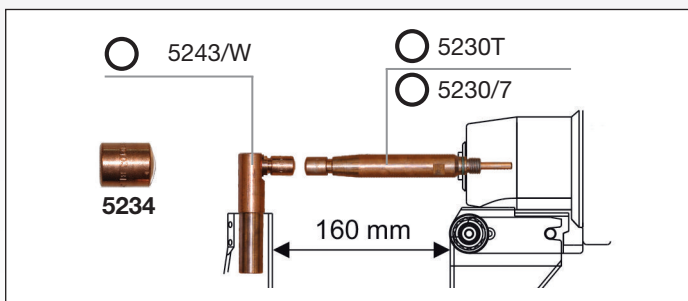
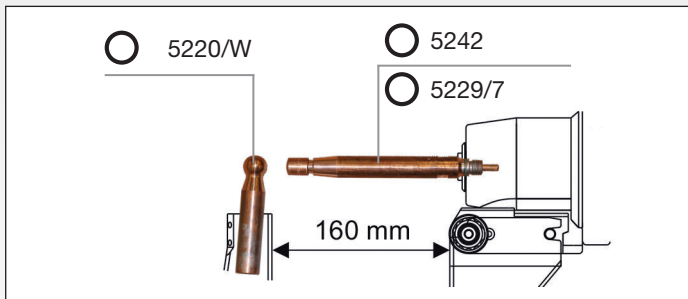
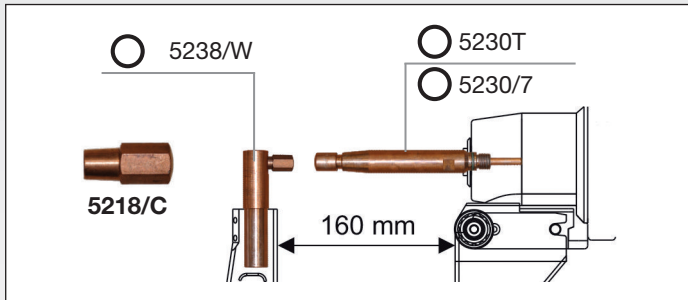
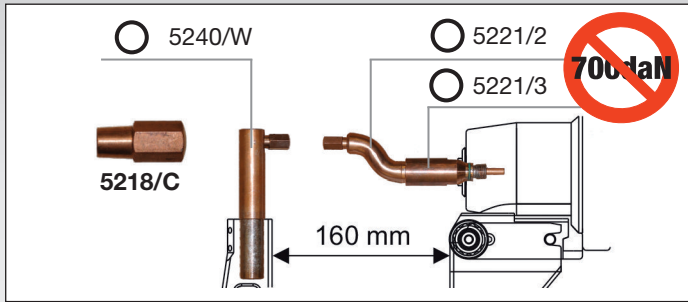
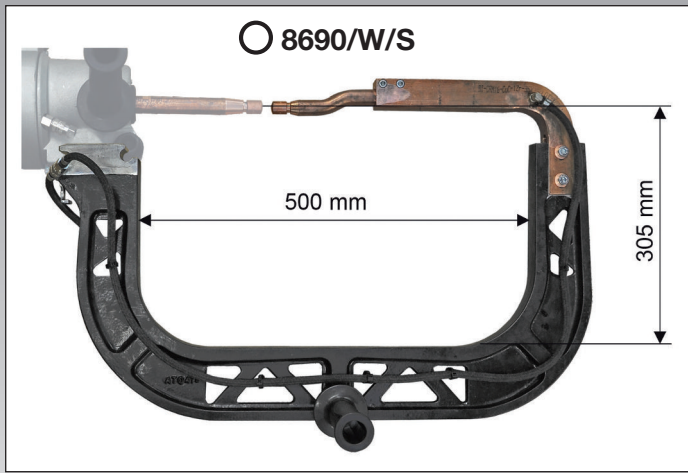

○ 8689

○ 5221/2

○ 5221/3

NUR FÜR 8669|8679H|8679TS

NUR FÜR 5221/2

● STANDARD ○ OPTIONAL

**8680/Pack01**

8688/W/S

- 8689
- 5223/W
- 5230T
- 5220/WP

**8680/7/Pack01**

8688/W/S

- 8689
- 5223/W
- 5230/7
- 5220/WP

**8680/Pack02**

8686/W/S

- 5221/2
- 5221/3
- 5240/W

**8680/7/Pack02**

8686/W/S

- 5221/2
- 5221/7
- 5240/W